

BI-METTALIC LUGS

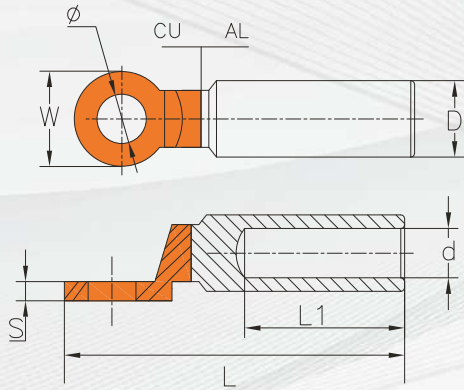

FEATURES & TECHNICAL SPECIFICATION

- Suitable for aluminum to copper terminations
- Aluminium barrel is filled by neutral grease and covered by cap
- Friction welded
- Material: CU 99.9%, AL 99.5%

Model No.	$\phi \pm 0.3$	$D \pm 0.2$	$d \pm 0.2$	$L \pm 2$	$L1 \pm 2$	$W \pm 0.2$	$S \pm 0.2$
JG-DTL-2-16	10.5	16	6.5	80	42	20	3.0
JG-DTL-2-25	10.5	16	7.5	80	42	20	3.0
JG-DTL-2-35	10.5	16	8.5	80	42	20	3.0
JG-DTL-2-50	12.8	20	9.8	90	43	25	4.5
JG-DTL-2-70	12.8	20	11.5	90	43	25	4.5
JG-DTL-2-95	12.8	20	13.5	90	43	25	4.5
JG-DTL-2-120	12.8	25	15.0	114	60	30	5.5
JG-DTL-2-150	12.8	25	16.5	114	60	30	5.5
JG-DTL-2-185	12.8	32	18.5	118	60	35	6.0
JG-DTL-2-240	12.8	32	21.5	118	60	35	6.0
JG-DTL-2-300	12.8	34	23.5	127	72	35	6.0
JG-DTL-2-400	17.0	40	26.0	160	93	36	7.0
JG-DTL-2-630	17.0	47	32.5	180	94	50	9.0

